

RT5714-K1WSC Tiny, 360nA Low Quiescent Current, 0.5A/1A HCOT nanoPower Buck Converter Converter

General Description

The RT5714 is a high efficiency synchronous step-down converter featuring typ. 360nA quiescent current. This document explains the function and use of the RT5714 evaluation board (EVB), and provides information to related setting of the evaluation board.

Table of Contents

General Description	1
Performance Sepcification Summary	2
Power-up Procedure	2
Detailed Description of Hardware	4
Bill of Materials.....	6
Typical Applications	7
Evaluation Board Layout.....	10
More Information.....	12
Important Notice for Richtek Evaluation Board.....	12

Performance Specification Summary

Summary of the RT5714 Evaluation Board performance specification is provided in Table 1. The ambient temperature is 25°C.

Table 1. RT5714 Evaluation Board Performance Specification Summary

Specification	Test Conditions	Min	Typ	Max	Unit
Input Voltage Range		2.2	--	5.5	V
Output Current		0	--	0.6	A
Operation Frequency		--	1.2	--	MHz
IQ_Non-SW	V _{OUT} = 1.8V, I _{OUT} = 0A, EN = VIN, non-switching	--	360	800	nA
IQSW	V _{OUT} = 1.8V, I _{OUT} = 0A, EN = VIN, switching	--	460	1200	
ISHDN	EN = GND	--	0.2	1	uA
VOUT_ACC10	V _{OUT} = 1.8V, I _{OUT} = 10mA	-2.5	--	2.5	%
VOUT_ACC100	V _{OUT} = 1.8V, I _{OUT} = 100mA	-2	--	2	%

Power-up Procedure

Suggestion Required Equipments

- RT5714 Evaluation Board
- DC power supply capable of at least 5.5V and 3A
- Electronic load capable of 3A
- Function Generator
- Oscilloscope

Quick Start Procedures

The Evaluation Board is fully assembled and tested. Follow the steps below to verify board operation. Do not turn on supplies until all connections are made. When measuring the output voltage ripple, care must be taken to avoid a long ground lead on the oscilloscope probe. Measure the output voltage ripple by touching the probe tip and ground ring directly across the last output capacitor.

Proper measurement equipment setup and follow the procedure below.

- 1) Set output voltage by VSEL pin(L for Output1, H for Output2).
- 2) With power off, connect the input power supply to VIN and GND pins.
- 3) With power off, connect the electronic load between the VOUT and nearest GND pins.
- 4) Turn on the power supply at the input. Make sure that the input voltage does not exceeds 5.5V on the Evaluation Board.
- 5) Enabled the RT5714 by EN pin. When the EN pin is higher than the threshold of logic-high IC goes to normal operation; When EN pin High transfer Low into shutdown mode, the converter stops switching, internal control circuitry is turned off and trigger discharge function. That discharge function will close after count 10ms (typ.).

- 6) To verify the output voltage VOUT. If VSEL connect to L, output voltage of the RT5714 measurement is Output-1; If VSEL connect to H, output voltage of the RT5714 measurement is Output-2.
- 7) Check for the proper output voltage using a voltmeter.
- 8) Once the proper output voltage is established, adjust the load within the operating ranges and observe the output voltage regulation, ripple voltage, efficiency and other performance.

Detailed Description of Hardware

Headers Description and Placement

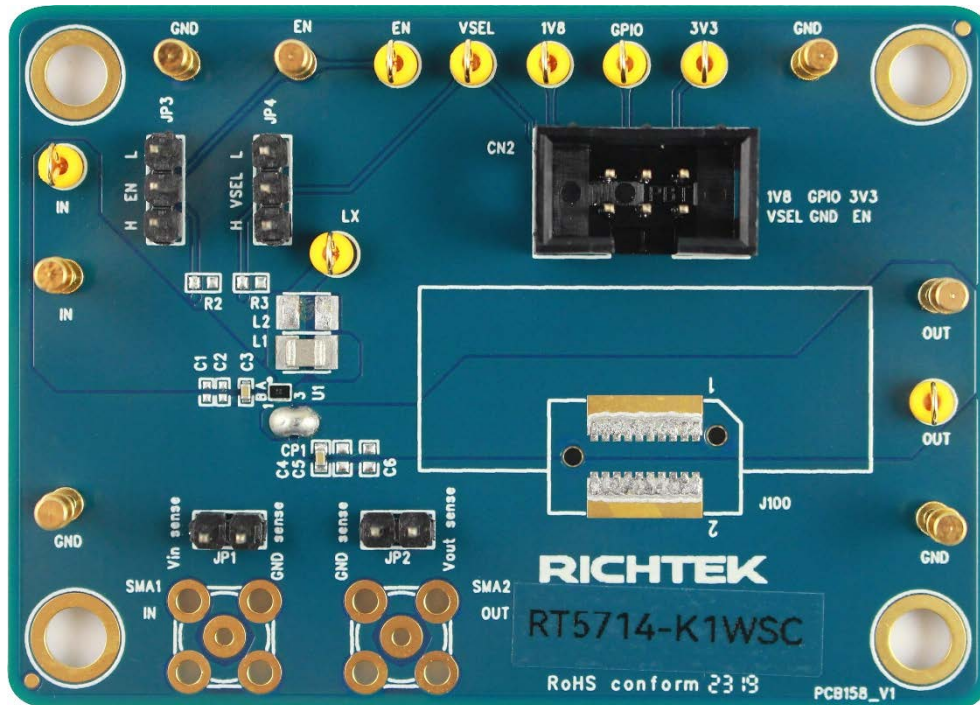

Carefully inspect all the components used in the EVB according to the following Bill of Materials table, and then make sure all the components are undamaged and correctly installed. If there is any missing or damaged component, which may occur during transportation, please contact our distributors or e-mail us at evb_service@richtek.com.

Test Points

The EVB is provided with the test points and pin names listed in the table below.

Test Point/ Pin Name	Function
VIN	Input voltage.
VOUT	Output voltage.
GND	Ground.
EN	Enable test point.
LX	Switching signal.
VSEL	Output voltage select.

Output Voltage Selection

The RT5714 provides 2 level output voltages which can be programmed via the voltage select pin VSEL.

Table 2 indicates the setting to individual output voltage.

Table 2. Output Voltage Setting

Output-1 (VSEL = 0)	Code	Output-2 (VSEL = 1)	Code
0.525V	A	0.525V	A
0.55V	B	0.55V	B
0.58V	C	0.58V	C
0.6V	D	0.6V	D
0.625V	E	0.625V	E
0.65V	F	0.65V	F
0.675V	G	0.675V	G
0.7V	H	0.7V	H
0.75V	J	0.75V	J
0.8V	K	0.8V	K
0.85V	L	0.85V	L
0.9V	M	0.9V	M
0.95V	N	0.95V	N
1V	P	1V	P
1.05V	Q	1.05V	Q
1.1V	R	1.1V	R
1.15V	S	1.15V	S
1.2V	T	1.2V	T
1.3V	U	1.3V	U
1.4V	V	1.4V	V
1.5V	W	1.5V	W
1.6V	Y	1.6V	Y
1.7V	Z	1.7V	Z
1.8V	1	1.8V	1
1.9V	2	1.9V	2
2V	3	2V	3
2.1V	4	2.1V	4
2.5V	5	2.5V	5
2.75V	6	2.75V	6
3V	7	3V	7
3.3V	8	3.3V	8
4V	9	4V	9

Bill of Materials

RT5714 WL-CSP Package						
Reference	Count	Part Number	Value	Description	Package	Manufacturer
U1	1	RT5714-K1WSC	RT5714-K1WSC	Step-Down Converter	WL-CSP-6B 1.415x0.885 (BSC)	RICHTEK
C3, C4	2	GRM155R60J106ME15	10 μ F	10 μ F/6.3V/X5R	0402	Murata
L1	1	1239AS-H-2R2M	2.2 μ H	2.2 μ H	2025	TDK

Typical Applications

EVB Schematic Diagram

For RT5714 WL-CSP Package

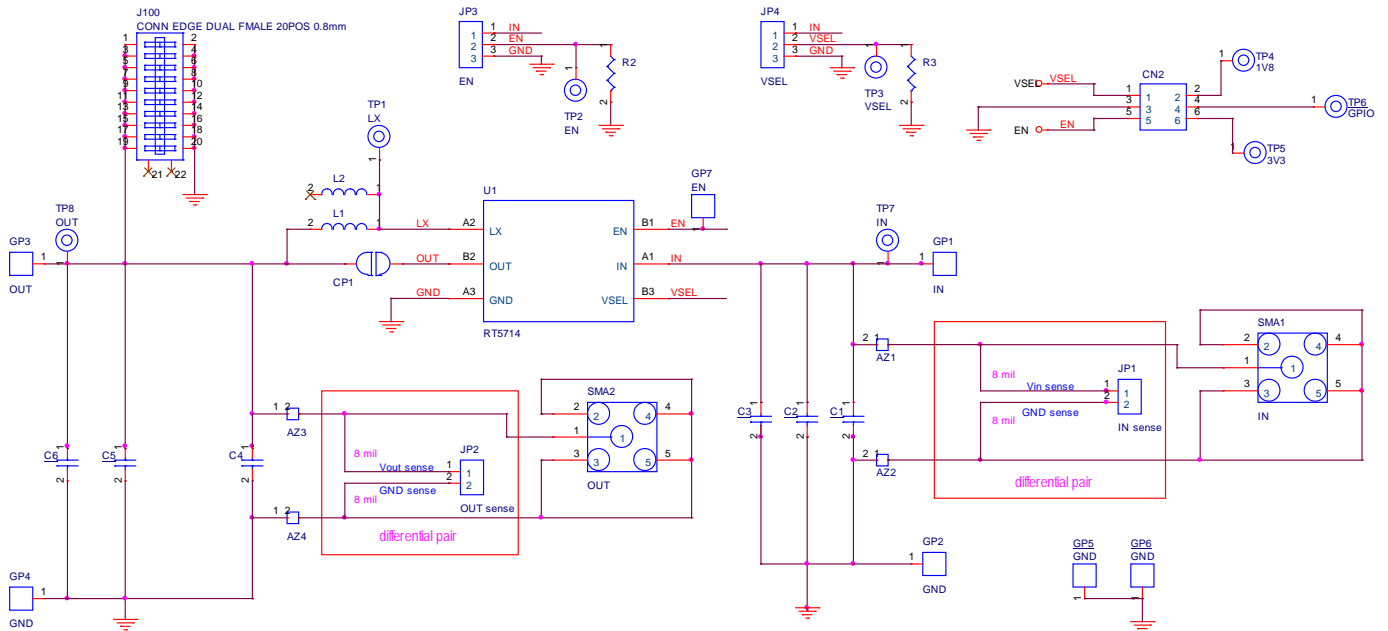

1. The capacitance values of the input and output capacitors will influence the input and output voltage ripple.
2. MLCC capacitors have degrading capacitance at DC bias voltage, and especially smaller size MLCC capacitors will have much lower capacitance.

Measure Result

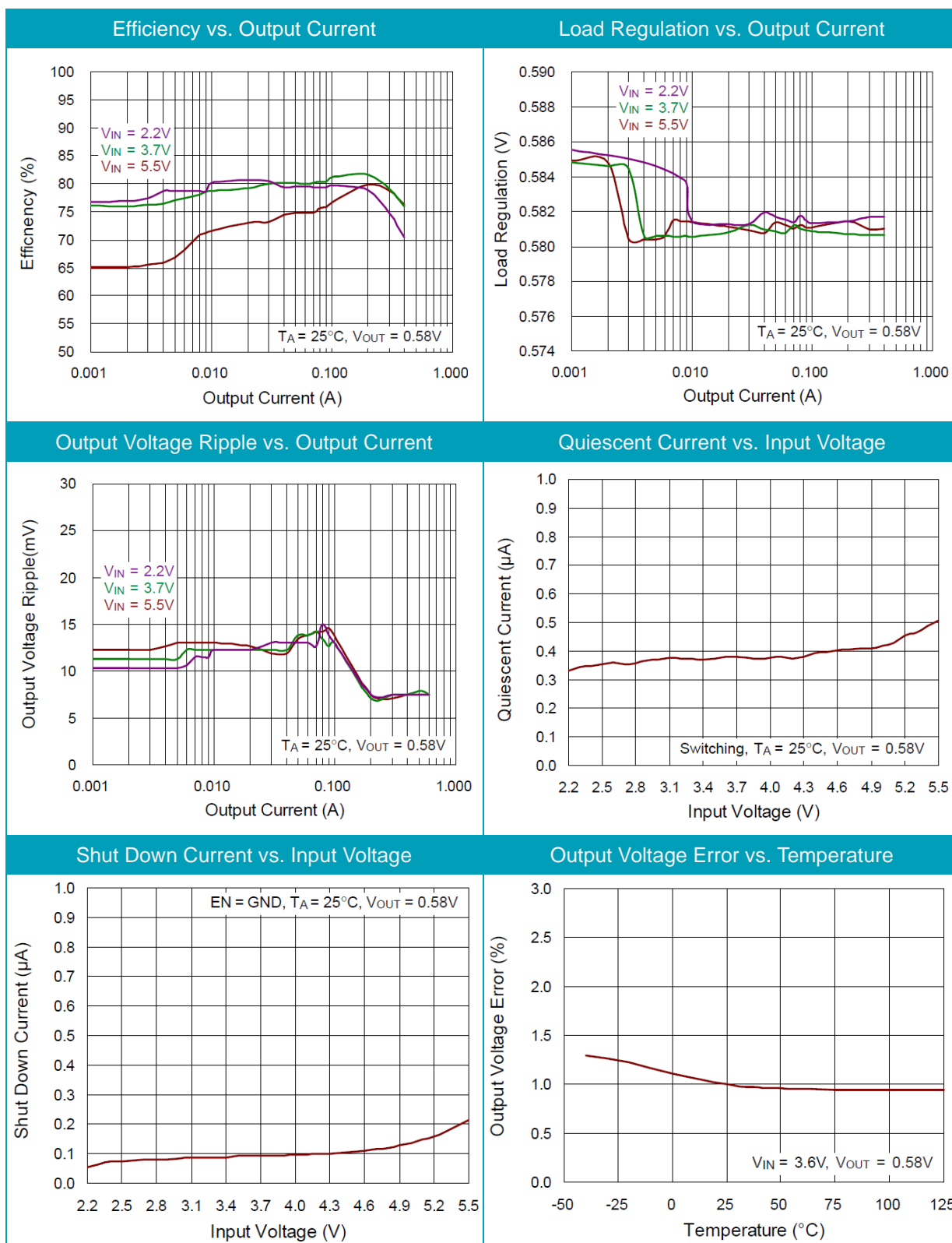



Note: When measuring the input or output voltage ripple, care must be taken to avoid a long ground lead on the oscilloscope probe. Measure the output voltage ripple by touching the probe tip directly across the output capacitor.

Evaluation Board Layout

Figure 1 to Figure 4 are RT5714 WL-CSP package Evaluation Board layout. This board size is 70mm x 50mm and is constructed on four-layer PCB.

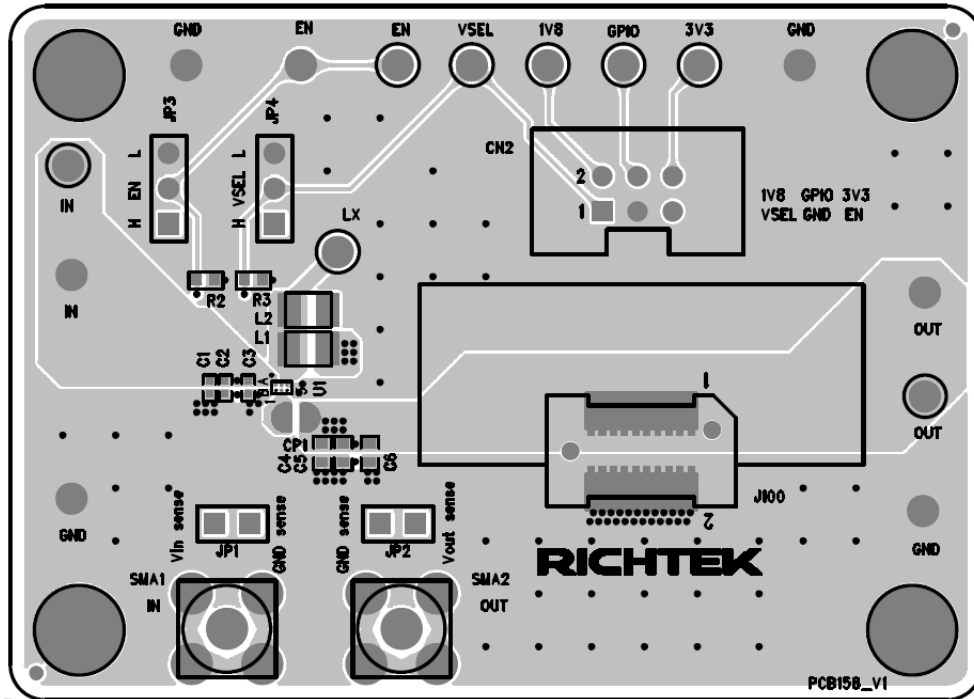

Figure 1. Top View (1st layer)

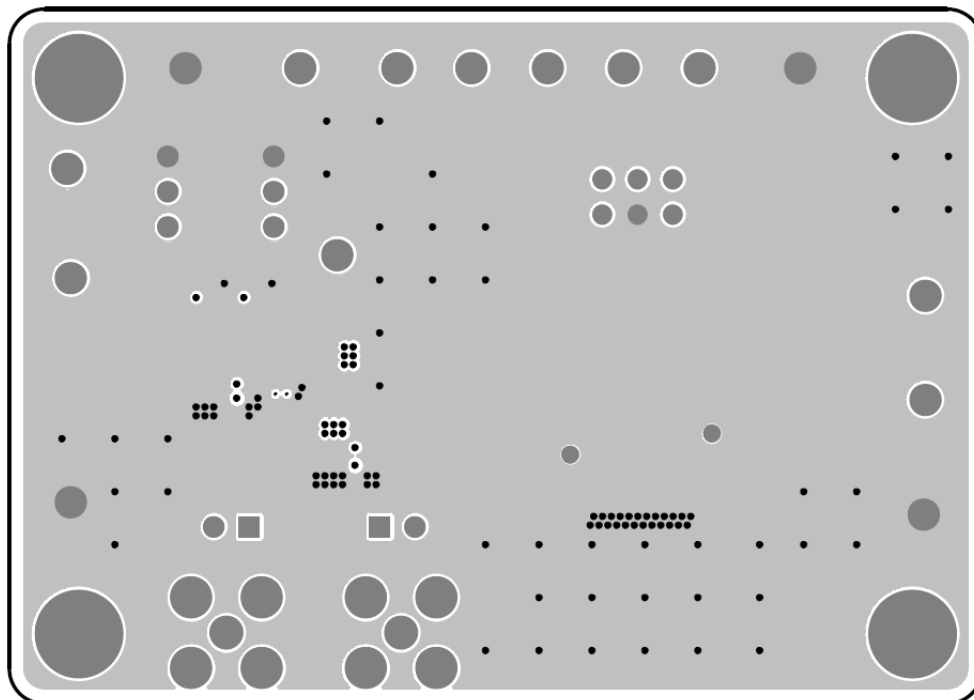

Figure 2. PCB Layout—Inner Side (2nd Layer)

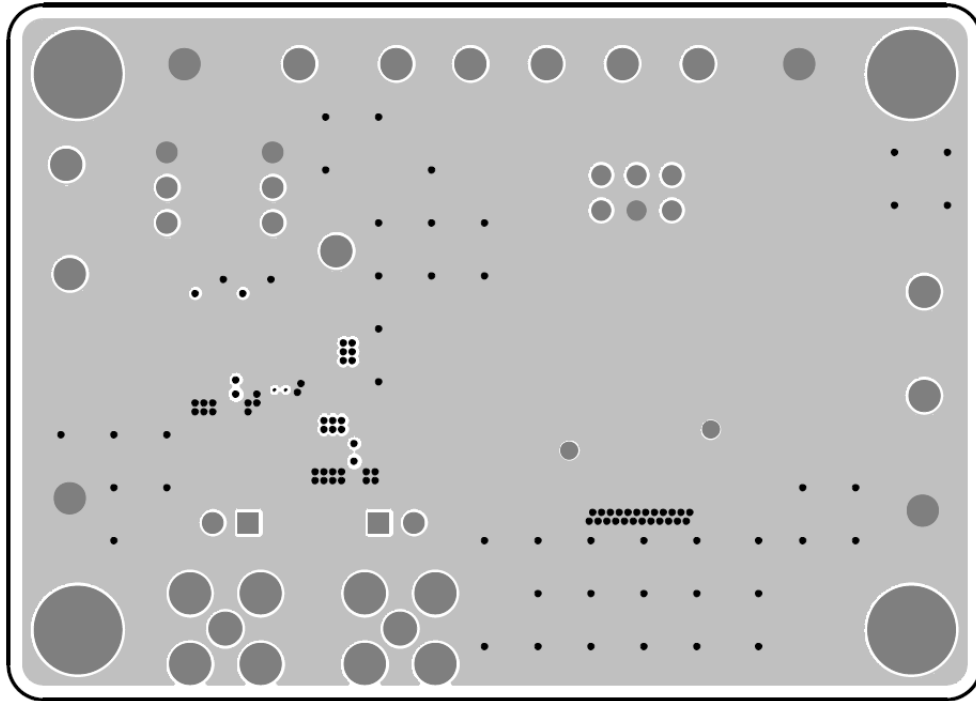

Figure 3. PCB Layout—Inner Side (3rd Layer)

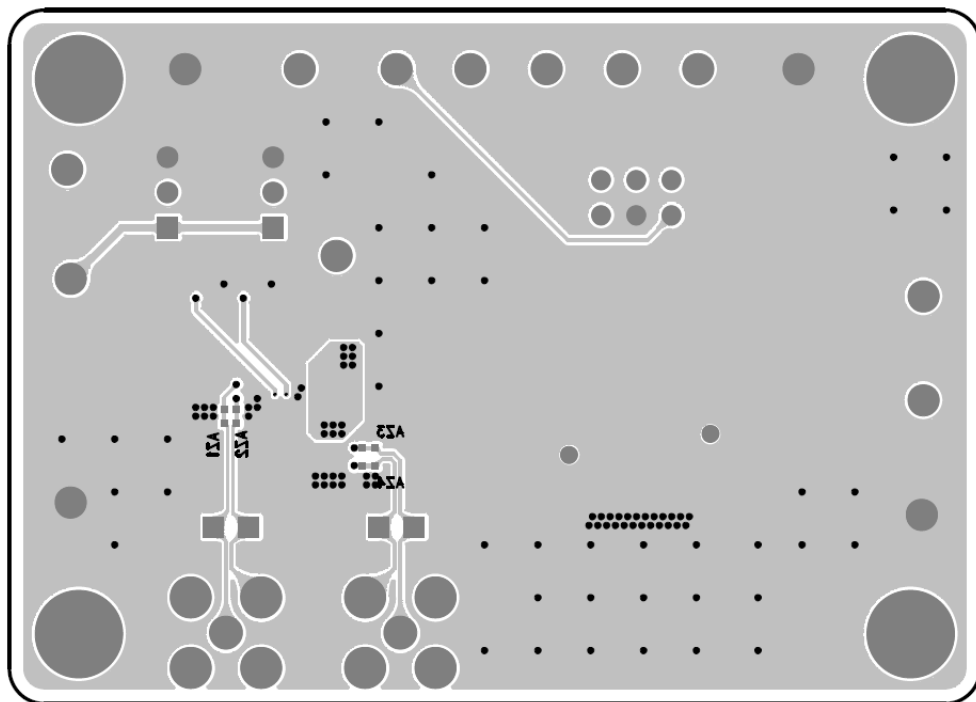

Figure 4. Bottom View (4th Layer)

More Information

For more information, please find the related datasheet or application notes from Richtek website

<http://www.richtek.com>.

Important Notice for Richtek Evaluation Board

THIS DOCUMENT IS FOR REFERENCE ONLY, NOTHING CONTAINED IN THIS DOCUMENT SHALL BE CONSTRUED AS RICHTEK'S WARRANTY, EXPRESS OR IMPLIED, UNDER CONTRACT, TORT OR STATUTORY, WITH RESPECT TO THE PRESENTATION HEREIN. IN NO EVENT SHALL RICHTEK BE LIABLE TO BUYER OR USER FOR ANY AND ALL DAMAGES INCLUDING WITHOUT LIMITATION TO DIRECT, INDIRECT, SPECIAL, PUNITIVE OR CONSEQUENTIAL DAMAGES.